

# SPEEDWATCH

## *Wireless Speed Computer Instruction manual*



## **1. Introduction**

The SPEEDWATCH wireless speed computer is a highly accurate means to measure speed through water of any low-speed watercraft such as a sailboat, yacht, kayak or small powered boats. Designed for the serious racer and the advanced users, the SPEEDWATCH gives valuable feedback on the performance of your watercraft.

The small impeller is placed under the craft, in a variety of mounting possibilities. When your boat or kayak is moving through the water, the impeller rotates creating a magnetic field that penetrates through hull without wires. This magnetic field is received by the sensitive sensor at the end of a cable on the transmitter, which is placed within 30 cm from the impeller. The transmitter then sends out a low-frequency radio signal that is received by the display up to 5 meters. The signal is processed and displayed as instant speed.

The SPEEDWATCH uses this speed signal to calculate the instant, balanced, and maximum speed as well as the trip and total distance. The SPEEDWATCH outperforms any GPS with regards to precise speed and distance measurement, allowing for minute changes in performance to

be registered and adjusted. The SPEEDWATCH becomes an invaluable tool when sailing or rowing in currents, as it measures true speed through water, rather than average speed over land like a GPS.

The magnetized impeller requires no power source, the transmitter uses a 9V battery, and the display includes a long-life Lithium battery, good for hundreds of hours of use.

### **FUNCTION**

**Speed** : Instant, balanced, maximum, average

**Distance** : Trip, total

**Chronometer** : Automatic or manual

**Countdown Timer** : 10, 6, 5, 3, or 1 minute(s)

**Time of day** : AM/PM mode

**Backlight** : Red backlight

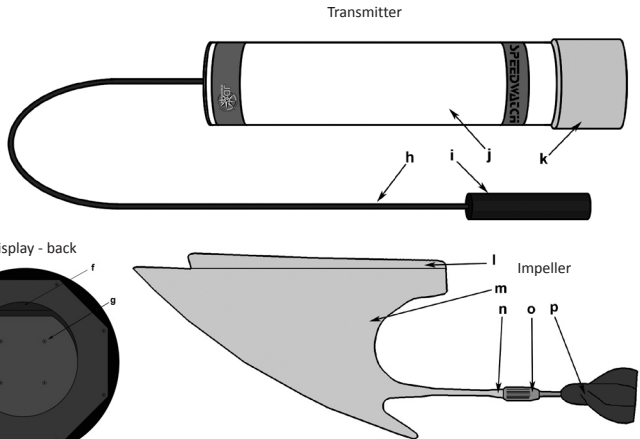
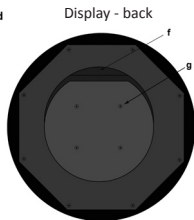
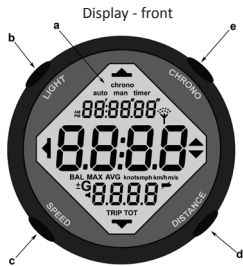

### DISPLAY

- a) LCD
- b) Backlight button
- c) Speed select button
- d) Distance select button
- e) Chronometer start button
- f) Spring snap for mounting plate
- g) Battery cover (four screws)

### TRANSMITTER

- h) 0.3 m cable
- i) Sensor for impeller
- j) Transmitter body
- k) Battery cap

### IMPELLER

- l) Mounting plate
- m) Fin
- n) Threaded shaft
- o) Threaded base
- p) Magnetized impeller

## 2. Display Screen Description

- a) Automatic (auto) or manual (man) chronometer, or countdown timer (timer)
- b) Chronometer display, hours: minutes' seconds''
- c) Receiving transmission
- d) Speed display
- e) Speed increase or decrease
- f) Units of measure (knots, mph, km/h, ou m/s)
- g) Low battery indicator (for display)
- h) Trip (TRIP) or total (TOT) distance
- i) Distance display
- j) Balanced (BAL), maximum (MAX), or average (AVG) speed

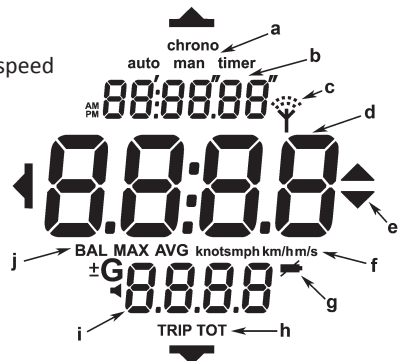

### 3. Start up the Instrument

#### DISPLAY

From the factory, the SPEEDWATCH is in a low power state, with the time flashing. Press any button to enter normal mode.

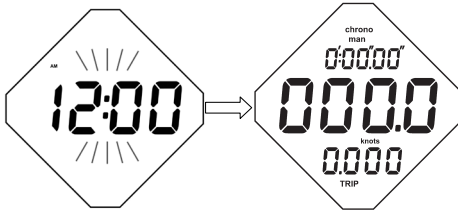

The SPEEDWATCH is now in Manual Mode; it will only receive data from the transmitter when the CHRONO button is pressed and the impeller is rotating. The default speed is knots, which can be changed to mph, km/h, or m/s.

#### IMPELLER

The SPEEDWATCH impeller needs to be screwed on to either the white fin mount (1), the large black fin (2) or the rudder black fin mount (3). The impeller is magnetized and creates a magnetic pulse when rotating. This magnetic pulse is received by the transmitter and transmitted to the display. The display cannot sense the impeller directly; the transmitter must be on.

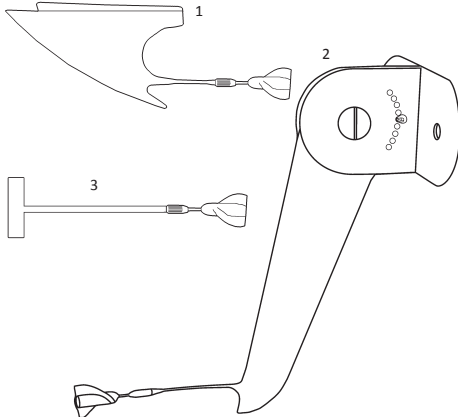

#### TRANSMITTER

The SPEEDWATCH Transmitter requires a 9V battery to operate; this is included in your system. To install the battery, gently pull the cap exposing the battery compartment. Install the 9V battery and replace the battery cap. Be sure to press the cap back on fully to form the water tight seal. Failure to do this could result in the 9V battery failing. The electronics in the SPEEDWATCH transmitter are completely factory sealed. Do not attempt to open the case exposing the electronics, or failure can occur.

It is not necessary to remove the battery except for long period (winter storage) because the power consumption is very low if no magnetic field is received.

Red flashes appear on the bottom side when the transmitter receives the magnetic signal from the impeller.

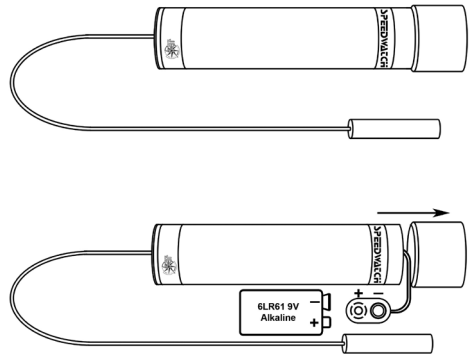

## 4. Programming the SPEEDWATCH

Enter in the programming mode to set the:

- Chronometer – manual or automatic
- Countdown timer
- Speed unit
- Time
- Balanced speed duration
- Sensor clibration

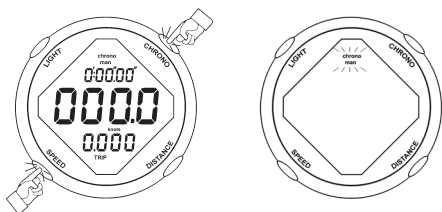

**To enter in the programming mode, you have to be either in MANUAL chronometer mode with stopped countdown timer or in automatic and not read the signal.**

Press and hold three seconds the both SPEED and CHRONO buttons to enter in the programming mode. “CHRONO” and “MAN” (manual) or “AUTO” (automatic) will flash. Press the DISTANCE or CHRONO buttons to change settings, and on the SPEED button to confirm the parameters and advance to the next item. Press and hold the SPEED and CHORNO buttons for three seconds to accept all parameters and go back to the normal operating mode.

### CHRONOMETER – MANUAL OR AUTOMATIC

Press the CHRONO or DISTANCE buttons to alternate between the manual or automatic chronometer. Press the SPEED button to confirm the settings and advance.

### COUNTDOWN TIMER

Press the CHRONO or DISTANCE button to select the countdown timer. It can be set to 10, 6, 5, 3 or 1 minutes. Press the SPEED button to confirm the settings and advance. If the countdown is changed, the SPEEDWATCH will enter the countdown mode upon existing the programming mode by pressing CHRONO and SPEED.

### SPEED UNIT

Press the CHRONO or DISTANCE buttons to select the speed unit. It can be set in km/h (kilometre per hour), m/s (meter per second), knots or mph (miles per hour). Press the SPEED button to confirm the settings and advance.

### TIME SETTING

Press the CHRONO button to advance the time, and the DISTANCE button to move the time back. Press and hold the button to change the time faster. It will start minute by minute for the first ten minute change, then every ten minutes for the next hour change, and then every hour. The time is in AM/PM mode. Press the SPEED button to confirm setting and advance.

### BALANCED SPEED

The balanced speed setting averages the instant speed over the selected time period to provide a balanced speed reading. This can be set from 2 seconds to 60 seconds, with varying intervals (2, 3, 4, 5, 6, 8, 10, 12, 15, 20, 30, or 60 seconds). Press the CHRONO button to increase the time, and the DISTANCE to decrease the time. Press the SPEED button to confirm setting and advance.

### SPEED SENSOR CLIBRATION

The SPEEDWATCH can be set to accept another impeller, for example a style sensor “paddle-wheel”.

**The calibration for the SPEEDWATCH impeller is 40.0.** The minimum value is 10.0, the maximum value is 2000. Press and hold the CHRONO button to increase or the DISTANCE button to reduce faster the value. For other sensors than the SPEEDWATCH sensor, you have to know the setting for your impeller. Press the SPEED button to confirm the settings and advance.

**The programming of the SPEEDWATCH is now complete. Press and hold both the SPEED and CHRONO buttons for three seconds to confirm all settings and enter normal operating mode.**

### GENERAL RESET

Press the four buttons together to reset your SPEEDWATCH.

## 5. Basic Operating Mode

### GENERAL BUTTONS USE

**LIGHT Button:** Turns on the backlight for 5 seconds (in any mode).

**SPEED Button:** Select the displayed speed in bold character: instant, balanced, maximum or trip average.

**DISTANCE Button:** Select the displayed distance, trip or total.

**CHRONO Button:** Starts and stops the chronometer and speed reading. Also starts and pauses the countdown timer.

### MEASURING SPEED AND DISTANCE

The SPEEDWATCH measures the actual speed through water, not speed over land as with a GPS. The small impeller is mounted under the boat or kayak and generates a magnetic field when rotating. This magnetic field is received by the transmitter through the hull with no wires, up to 30 centimeter. The transmitter sends out a low frequency radio signal which is received up to 5 meter by the display. To properly read speed data, the impeller and transmitter should be mounted properly. Please see the MOUNTING section for detailed instructions. There are two modes for measuring speed through the water, MANUAL or AUTOMATIC. In MANUAL mode, the timer is started and stopped by pressing the CHRONO button. Speed is only measured and registered when the timer is ON. In AUTOMATIC mode, the timer starts when a signal is received from the transmitter.

To reset the trip distance and the chronometer, press the CHRONO button in manual mode to pause the chronometer. Then, press and hold the DISTANCE button. To reset the total distance, press and hold 10 seconds the DISTANCE button.

### COUNTDOWN TIMER

The SPEEDWATCH can be set to provide a countdown timer for the start of races. To enter the programming mode, you must be either in MANUAL chronometer mode with the timer stopped or in automatic and reading any signal (the timer will be stopped). Press and hold both the SPEED and CHRONO buttons for three seconds to enter the programming mode. Press the SPEED button to advance to the timer setting. Press the CHRONO or DISTANCE buttons to select the countdown timer. This can be set to 10, 6, 5, 3, or 1 minutes.

Press the SPEED and CHRONO buttons for three seconds to exit the programming mode. The time is displayed at the top of the LCD, the countdown timer is displayed in the middle of the screen.

Press the CHRONO button to start the countdown timer. All other buttons are disabled, except for the LIGHT button. Press the CHRONO button to pause the countdown. The timer will countdown, with a single beep at each minute. At one minute left, a double beep will sound each ten seconds. At ten seconds, the SPEEDWATCH will beep three times each second until 0:00. At 0:00 the signal will sound for two full seconds. When the countdown timer reaches 0:00, the SPEEDWATCH will enter the normal operating mode, measuring speed and distance. The chronometer is reset to MANUAL, and can be paused by pressing the CHRONO button. To cancel the countdown timer, press the CHRONO button to pause the countdown. Then press and hold the SPEED and CHRONO buttons for three seconds to enter the programming mode. Do not change the timer setting; exit the programming mode by pressing and holding the SPEED and CHRONO buttons for three seconds.



## 6. Mounting the Speedwatch

### IMPELLER

The impeller is fixed on the watercraft, with many options. We recommend you to fix the impeller at the prow, to avoid turbulences.

### TRANSMITTER

The transmitter is inside the hull with the magnetic sensor at 30 centimeters from the impeller. The transmitter has to be fixed with the "Dual Lock" to avoid any movement.

### DISPLAY

The display can be placed everywhere in the boat until **5 meters** from the transmitter. A plastic mounting support is joined to the display and can be mounting on a flat area or the Velcro strap can be used to wrap around the mast or the leg. The transmitter has to be fixed to avoid movement but the display can be moved while it receives data.

- Impeller on rudder attachment
- Impeller on fin attachment
- Transmitter
- Display (not to scale)



### IMPELLER, TRANSMITTER AND DISPLAY ORIENTATION

To have a maximum distance between the impeller and the transmitter, we recommend you to put the transmitter in perpendicular position to the impeller as shown in the picture below. The distance between the transmitter and the display is maximum if the display is perpendicular to the transmitter.

Three mounting systems are included in the SPEEDWATCH kit; a removable fin mount, a large fin to be fixed on the keel back side and a rudder mount.

The rudder mount has a black clip that rests on the edge of the rudder, the strips of adhesive are then wrapped around the clip and secures it to the rudder. The impeller is screwed onto the end.

The large blade fin to be fixed on the keel back side can either be attached with VHB adhesive tape or by screws. The cotter pin can be moved to adjust the movement of the fin to allow the impeller to be out of the water.

The white fin mount has a base plate that is attached to the hull, either with the VHB adhesive tape or by screws. The fin can then be inserted and removed to store the impeller while not in use. The impeller is screwed onto the end.

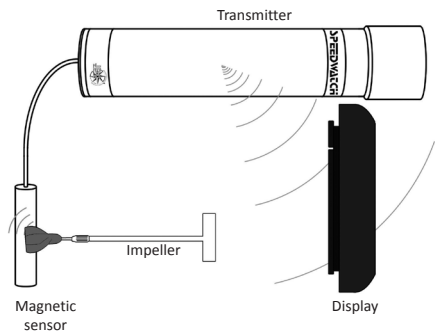

## IMPELLER MOUNTING OPTIONS

### Small white fin mount:

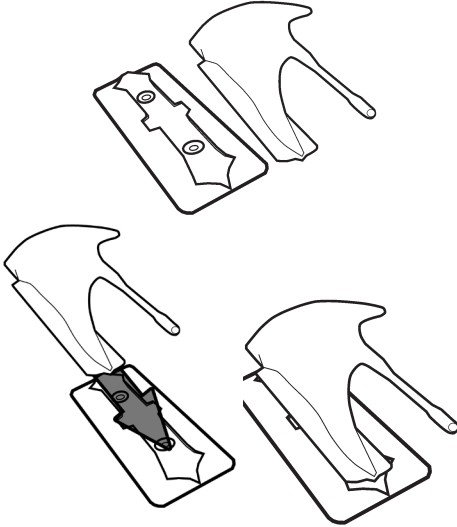

Carefully clean the area before to stick the adhesive and wait 24 hours before submersion for best adhesion.

### Rudder attachment:

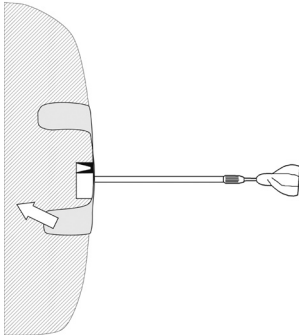

### Large blade fin mount:

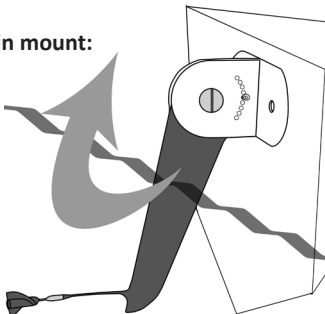

## 7. Speed Sensor Calibration

This operation allows the SPEEDWATCH to be adjusted for an exceptional accuracy. It's normally not necessary. However, the SPEEDWATCH can be calibrated with an existing speed sensor to accuracy measure the speed.



Calibration is carried out from the programming mode. Press and hold both the SPEED and CHRONO buttons for three seconds to enter the programming mode. "chrono" and "man" (manual) or "auto" (automatic) will flash. Press the SPEED button five times to advance to the calibration mode. The proper calibration is 40.0 for the SPEEDWATCH impeller. To adjust the SPEEDWATCH, increase this number (CHRONO button) to decrease the speed reading. Decrease this number (DISTANCE button) to increase the speed reading. The displayed number corresponds to the distance in mm done by one turn of the impeller or the circumference of the wheel. Press and hold the SPEED and CHRONO buttons for 3 seconds to accept all settings and go back to the normal operating mode.

## 8. Technical Specifications

### **IMPELLER TRANSMISSION**

The impellers, fixed on synthetic sapphire bearings, are equipped with powerful magnets that generate magnetic impulses. These impulses are collected by coils (also called "sensor") and treated electronically to be display speed. The magnetic impulses can go through any materials: fibreglass, carbon fibre, aramid fibre, wood, plastic, aluminium, stainless steel, etc. It is why you do not need to pierce the hull. This system is very sensitive; it can display a value near an electrical motor or an electrical light, even if the impeller does not turn. This is completely normal and does not affect the reading when the impeller turns.

### **TRANSMITTER RANGE**

The SPEEDWATCH transmitter operates on a low-frequency (8 kHz) which is wireless display. Many screens can be used for one transmitter. The range is ruled to provide the maximum distance in the watercraft but it cannot create an interference with other nearby system.

### **ACCURACY**

Tests were made at the Bremen University (Germany) in hydraulic canals. The results clearly showed that the SPEEDWATCH is in LDA (Laser Doppler Anemometry) 3% accuracy.

### **SPIN OUT**

All water tests made in real situation with high speed windsurfs (more than 30 knots) showed that there were no turbulences from the T attachment which hold the fin. Information transmitted by major European windsurf manufacturers.

### **TRAIL**

The impeller trail is 40 grams at 10 knots. Measurements were made in hydraulic canals in Bremen University in Germany.

## 9. Limite Warranty

JDC ELECTRONIC SA extends a 12 months' warranty over parts and labour for this instrument, effective from the date of purchase. JDC ELECTRONIC SA reserves the right to repair or replace any component which may have become faulty in the course of normal use. This repair or replacement shall be carried out at no charge to the customer (parts or labour). Transport costs however shall be borne by the customer. This warranty does not cover damages caused by an accident, abnormal or excessive use, or resulting from an unauthorised modification or repair.

For international warranty support, contact your dealer.

Developed and manufactured by:  
**JDC ELECTRONIC SA**  
Rue des Uttins 40, 1400 Yverdon-les-Bains,  
Switzerland  
Phone: ++41 (24) 445 2121  
Fax: ++41 (24) 445 2123  
e-mail: info@jdc.ch  
Internet: www.jdc.ch

